

**Identification and Overview**

**Outside Air Units - Humidity or Combination Temp/Humidity Sensors**

- 10 Points of Calibration from 10 to 90%RH
- Humidity Only or Temp./Humidity Combination
- Replaceable Filter
- ±2% and ±3%RH Accuracies
- BBox2 or BBox Enclosure Styles
- Wide Selection of Temperature Sensing Elements

Humidity control is an important aspect of any climate control system. Therefore, humidity sensors must be both accurate and dependable. Humidity transmitters are calibrated at 10 points from 10 to 90% RH for accuracy, eliminating field calibration.

The Outside Air Units are also extremely dependable, featuring two of the most watertight enclosures available today. The BBox and BBox2 are made of UV-resistant polycarbonate and carry an IP66 rating. The BBox is only available for units with a temperature transmitter and a humidity transmitter.

<b>Part #s:</b>	<b>N1-10K-2-H200-O-BB-A</b>	<b>N1-10K-2-H200-O-WP-A</b>
	<b>N1-10K-2-H300-O-BB2-A</b>	<b>N1-10K-2-H300-O-BB-A</b>
	<b>N1-10K-2-H300-O-WP-A</b>	<b>N1-H200-O-BB2-A</b>
	<b>N1-H200-O-WP-A</b>	



**Weather Shade**

External temperature, humidity and air quality are affected by radiant heat from the surfaces of Shade effectively blocks the radiant heat,

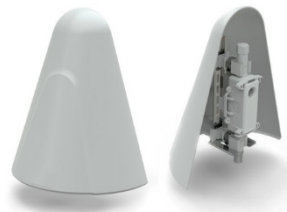

sensors buildings and parking lots. The Weather

**Specifications****Power:**

10 to 35 VDC.....	For 0 to 5 or 1 to 5 VDC or 4 to 20 mA Humidity Outputs
15 to 35 VDC.....	For 0 to 10 or 2 to 10 VDC Humidity Output
12 to 27 VAC.....	For 0 to 5 or 1 to 5 VDC Humidity Output
15 to 27 VAC.....	For 0 to 10 or 2 to 10 VDC Humidity Output

**Power Consumption:**

22 mA max. DC.....	For 0 to 5 or 1 to 5 VDC or 4 to 20 mA Humidity Outputs
6 mA max. DC.....	For 0 to 10 or 2 to 10 VDC Humidity Outputs
0.53 VA max. AC.....	For 0 to 5 or 1 to 5 VDC Humidity Output
0.14 VA max. AC.....	For 0 to 10 or 2 to 10 VDC Humidity Output

**Sensor:**

Humidity.....	Capacitive Polymer
Drift.....	0.5% per year
Response time.....	< 5 seconds in moving air
RH Linearity.....	Negligible, factory corrected linear from 10 to 80% RH
RH Hysteresis.....	Factory corrected to <1%
Opt. Temp.....	Passive RTD or Thermistor

**System Accuracy:**

2% RH.....	±2% (10 to 80% RH @ 25°C), ±3% (80 to 90% RH @ 25°C), Non-condensing
3% RH.....	±3% (10 to 90% RH @ 25°C), Non-condensing
Thermistor.....	±0.36°F (0.2°C) from 32 to 158°F (0 to 70°C) - High accuracy units are available
RTD.....	±0.55°F (0.31°C) @ 32°F (0°C) - High accuracy units are available

**Filter:** 80 micron sintered stainless steel filter**Output:** Selectable via wiring detail

Humidity.....	0 to 5, 1 to 5, 0 to 10 or 2 to 10VDC or 4 to 20mA at 0 to 100% RH
Opt. Temp.....	Resistance RTD or Thermistor

**Humidity Output Impedance:**

Current.....	700Ω@ 24VDC, Voltage drop is 10VDC (Supply Voltage DC – Transmitter voltage drop 10VDC) / 0.02 Amps = Max load
Impedance Voltage.....	10KΩ

**Probe Length:**

Duct.....	5.3" (13.5cm) Duct Insertion, 1" diameter
Outside Air.....	2.4" (6.1cm) Below Enclosure, 1" diameter

**Dimensions: W x H x D**

Weatherproof (WP).....	2.75" x 4.5" x 2.2", (70 x 114 x 55 mm)
BBox (BB).....	4.15" x 5" x 2.5", (105.4 x 127 x 63.5mm)
BBox2 (BB2).....	4.9" x 2.8" x 2.35", (124.8 x 71.6 x 59.7mm)

**Termination:** Open wire

Crimp.....	18 to 26 AWG with Sealant Filled Crimp Connector (N1-SFC1000-x00)
Wire Nut.....	26 to 16 AWG with Sealant Filled Wire Nut (N1-SFC2000-x00)

**Enclosure Material:**

Weatherproof (WP).....	Cast Aluminum
BBoxes (BB, BB2).....	Polycarbonate, UV resistant

**Enclosures Ratings:**

Weatherproof (WP).....	NEMA-3R
BBoxes (BB, BB2).....	NEMA-4, IP66, UL94V-0

**Environmental Operation Range:** -40° to 158°F (-40° to 70°C) • 0% to 100% RH**Approvals:** RoHS

**Outside Air Humidity Sensor Option Selection**

Use the Option Selection Guide below to create your custom part number. Replace the number and parenthesis with the designator for each selection. Skip the designator and dashes for optional selections that are not required in your configuration.

N1- ( #1 ) - ( #2 ) - ( #3 ) - A

**#1: TEMPERATURE SENSOR OR TRANSMITTER (OPTIONAL)**

1.8K.....	1.8K Thermistor
3K.....	3K Thermistor
10K-2.....	10K-2 Thermistor
10K-3.....	10K-3 Thermistor
10K-3[11K].....	10K-3[11K] Thermistor
20K.....	20K Thermistor
1K[375].....	1K Platinum RTD (375 curve)
1K[NI].....	1K $\Omega$ Nickel RTD
1K.....	1K Platinum RTD (385 curve)

Temperature Transmitters below require a BBox Enclosure

T1K[32 TO 212F].....	1K Plat. RTD Transmitter, 4 to 20 mA Output, 32 to 212 °F Range
T1K[20 TO 120F].....	1K Plat. RTD Transmitter, 4 to 20 mA Output, 20 to 120 °F Range
T1K[0 TO 100F].....	1K Plat. RTD Transmitter, 4 to 20 mA Output, 0 to 100 °F Range
T1K[0 TO 100C].....	1K Plat. RTD Transmitter, 4 to 20 mA Output, 0 to 100 °C Range
T1K[-7 TO 49C].....	1K Plat. RTD Transmitter, 4 to 20 mA Output, -7 to 49 °C Range
T1K[-18 TO 38C].....	1K Plat. RTD Transmitter, 4 to 20 mA Output, -18 to 38 °C Range

*Matched Transmitters are also available. Contact your representative for ordering.*

**#2: HUMIDITY OUTPUT (REQUIRED)**

H200.....	$\pm 2\%$ Humidity Transmitter with Output of 0 to 5 V
H215.....	$\pm 2\%$ Humidity Transmitter with Output of 1 to 5 V
H210.....	$\pm 2\%$ Humidity Transmitter with 0 to 10 V Output
H212.....	$\pm 2\%$ Humidity Transmitter with 2 to 10 V Output
H220.....	$\pm 2\%$ Humidity Transmitter with Output of 4 to 20mA
H300.....	$\pm 3\%$ Humidity Transmitter with Output of 0 to 5 V
H315.....	$\pm 3\%$ Humidity Transmitter with Output of 1 to 5 V
H310.....	$\pm 3\%$ Humidity Transmitter with 0 to 10 V Output
H312.....	$\pm 3\%$ Humidity Transmitter with 2 to 10 V Output
H320.....	$\pm 3\%$ Humidity Transmitter with Output of 4 to 20mA

**#3: ENCLOSURE STYLE (REQUIRED)**

O-BB2.....	BBox2 (IP66, NEMA 4X)
O-BB.....	BBox (for units with a humidity and temp transmitter only) (IP66, NEMA 4X)

*Additional options are available but not shown above.*

**Example Number:** N1-( 10K-2 ) - ( H200 ) - ( O-BB2 ) - A

**Actual Number (with parenthesis removed):** N1-10K-2-H200-O-BB2

**Description:** 10K-2 Thermistor, 0 to 5V or 4 to 20mA Humidity Output, BBox2 Enclosure.

**Mounting**

Mount in a permanently shaded area away from windows and doors. Do not mount in direct sunlight. Mount with the sensor probe pointed down. Drill a hole large enough for your sensor cable through your mounting surface. Mount the unit to the surface with the wiring knock out centered over the wiring hole. Pull the wiring into the unit and terminate using sealant filled connectors. Best practice is to seal the wiring hole with caulk after the wiring is installed. Be sure that the foam on the back of the unit makes a good weather tight seal.

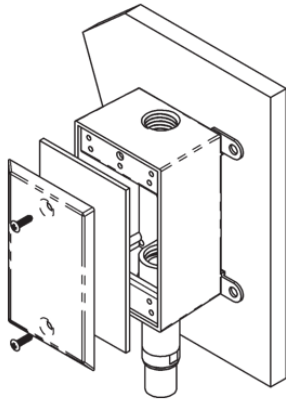

Outside Humidity in a Weatherproof (WP) Enclosure

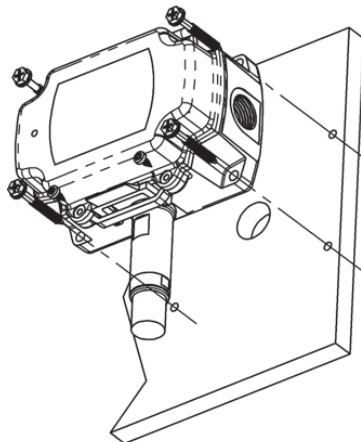

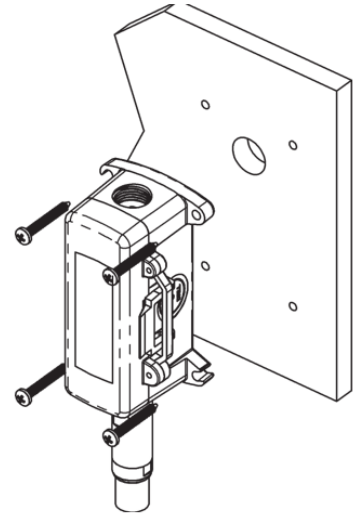

Outside Humidity in a BBox (BB) Enclosure



Outside Humidity in a BBox2 (BB2) Enclosure

**Wiring and Termination**

 <b>Warning</b>	<p>Wire the product with power disconnected. Proper supply voltage, polarity, and wiring connections are important to a successful installation. Not observing these recommendations may damage the product and will void the warranty.</p>
 <b>Caution</b>	<ul style="list-style-type: none"> <li>• Do NOT run this device's wiring in the same conduit as AC power wiring of NEC class 1, NEC class 2, NEC class 3 or with wiring used to supply highly inductive loads such as motors, contactors and relays. Tests show that fluctuating and inaccurate signal levels are possible when AC power wiring is present in the same conduit as the signal lines. If you are experiencing any of these difficulties, please contact your representative.</li> <li>• All wiring must comply with the National Electric Code (NEC) and local codes.</li> </ul>
 <b>Tip</b>	<p>We recommend using twisted pair of at least 22AWG and sealant filled connectors for all wire connections. Larger gauge wire may be required for long runs.</p>

#49483 – 9/7/23

**Table 1: Humidity Transmitter with 4 to 20mA Output**

Wire Color	Purpose	Note
White	Not Used	Not Used
Black	Humidity Output	4 to 20mA, To Analog Input of Controller
Red	Power	7 to 40VDC

**Table 2: Humidity Transmitter with 0 to 5 or 1 to 5 VDC Output**

Wire Color	Purpose	Note
White	Humidity Output	0 to 5 or 1 to 5 VDC, To Analog Input of Controller
Black	GND (Common)	Ground for Power and Humidity Output
Red	Power	7 to 40 VDC or 18 to 32 VAC

**Table 3: Humidity Transmitter with 0 to 10 or 2 to 10VDC Output**

Wire Color	Purpose	Note
White	Humidity Output	0 to 10 or 2 to 10VDC, To Analog Input of Controller
Black	GND (Common)	Ground for Power and Humidity Output
Red	Power	13 to 40 VDC or 18 to 32 VAC

**Table 4: Temperature Sensor Lead Wire Colors**

Thermistors		Platinum RTDs - 2 Wire	
1.8KΩ	Orange/Red	100Ω	Red/Red
2.2KΩ	Brown/White	1KΩ	Orange/Orange
3KΩ	Yellow/Black	<b>Nickel RTD</b>	
3.25KΩ	Brown/Green	1KΩ	Green/Green
3.3KΩ	Yellow/Brown	<b>Silicon RTD</b>	
10K-2Ω	Yellow/Yellow	2KΩ	Brown/Blue
10K-3Ω	Yellow/Red	<b>Platinum RTDs - 3 Wire</b>	
10K-3(11K)Ω	Yellow/Blue	100Ω	Red/Red/Black*
20KΩ	White/White	1KΩ	Orange/Orange/Black*
47KΩ	Yellow/Orange	*In the 3-Wire RTD sensors listed above, the two wires of similar color are connected together.	
50KΩ	White/Blue		
100KΩ	Yellow/White		

Additional sensors are available so your sensor may not be listed on this table.

**Wiring Diagram**

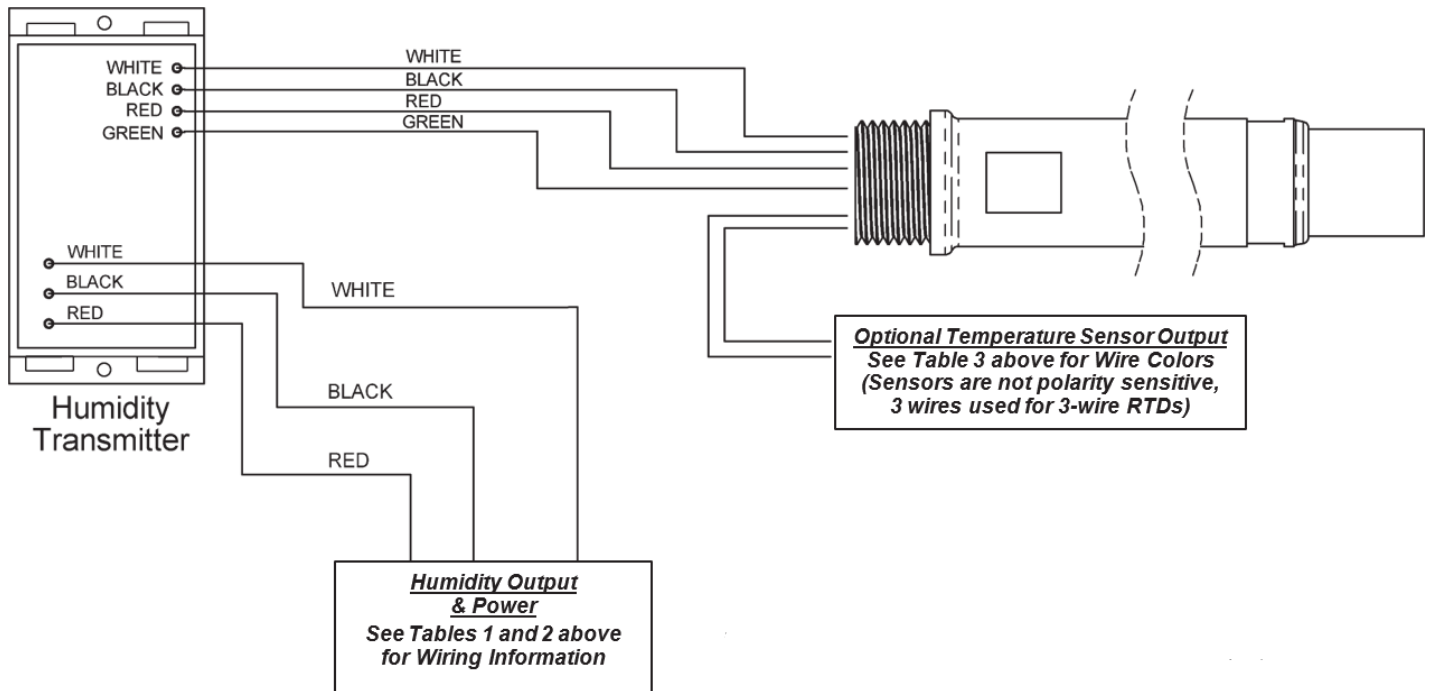

NOTE: ±2% and ±3% humidity transmitters ARE polarity sensitive as well as reverse polarity protected.

**Filter Care**

A sintered filter protects the humidity sensor from various airborne particles and may need periodic cleaning. To do this, gently unscrew the filter from the probe. Rinse the filter in warm soapy water and rinse until clean. A nylon brush may be used if necessary. Gently replace the filter by screwing it back into the probe. The filter should screw all the way into the probe. Hand tighten only.

**N1-HDOFS-A: Stainless Steel Sintered Filter Replacement for Outside Air Units**

Humidity Diagnostics													
Possible Problems:	Possible Solutions:												
Unit will not operate	Check for proper supply power. (See wiring diagram and power specifications)												
Humidity output is at its maximum	<ul style="list-style-type: none"> <li>Make sure the humidity sensor is wired properly.</li> <li>Verify humidity with a reference sensor. If humidity drops to 5% or below in the environment, the output will go to the maximum value.</li> </ul>												
Humidity output is at its minimum	Make sure the humidity sensor is wired properly.												
Humidity reading in controller's software appears to be off by more than the specified accuracy	<ul style="list-style-type: none"> <li>Check all software parameters</li> <li>Determine if the sensor is exposed to an external air source different from the intended measured environment or reference device.</li> </ul>												
<table border="1"> <thead> <tr> <th>Output</th> <th>Humidity Formula</th> </tr> </thead> <tbody> <tr> <td>4 to 20mA</td> <td><math>\%RH = (mA-4)/0.16</math></td> </tr> <tr> <td>0 to 5VDC</td> <td><math>\%RH = V/0.05</math></td> </tr> <tr> <td>1 to 5VDC</td> <td><math>\%RH = (V-1)/0.04</math></td> </tr> <tr> <td>0 to 10VDC</td> <td><math>\%RH = V/0.1</math></td> </tr> <tr> <td>2 to 10VDC</td> <td><math>\%RH = (V-2)/0.08</math></td> </tr> </tbody> </table>	Output	Humidity Formula	4 to 20mA	$\%RH = (mA-4)/0.16$	0 to 5VDC	$\%RH = V/0.05$	1 to 5VDC	$\%RH = (V-1)/0.04$	0 to 10VDC	$\%RH = V/0.1$	2 to 10VDC	$\%RH = (V-2)/0.08$	Check the Humidity transmitter output against a calibrated reference such as a 2% accurate hygrometer. Measure the humidity at the sensor's location using the reference meter, then calculate the humidity transmitter output using the humidity formula at left. Compare the calculated output to the actual humidity transmitter output (see the wiring diagram on page 2 for the humidity transmitter output wire colors). If the calculated output differs from the humidity transmitter output by more than 5%, contact technical support.
Output	Humidity Formula												
4 to 20mA	$\%RH = (mA-4)/0.16$												
0 to 5VDC	$\%RH = V/0.05$												
1 to 5VDC	$\%RH = (V-1)/0.04$												
0 to 10VDC	$\%RH = V/0.1$												
2 to 10VDC	$\%RH = (V-2)/0.08$												

Temperature Diagnostics	
Possible Problems:	Possible Solutions:
Controller reports Incorrect temperature	<ul style="list-style-type: none"> <li>Confirm the input is set up correctly in the controller's software</li> <li>Verify that the sensor wires are not physically shorted or open</li> <li>Check wiring for proper termination</li> <li>Measure the temperature at the temperature sensor's location using an accurate temperature standard. Disconnect the temperature sensor wires and measure the temperature sensor's resistance with an ohmmeter. Compare the temperature sensor's resistance to the appropriate temperature sensor table. If the measured resistance is different from the temperature table by more than 5%, call technical support.</li> </ul>

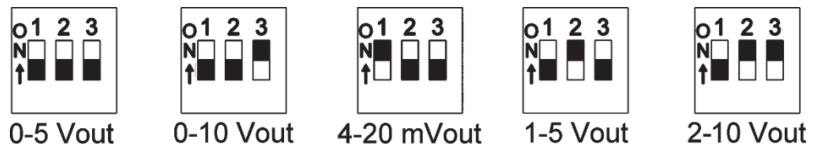

**Humidity Output DIP Switch Note:**

The transmitter circuit board may have a three-position DIP switch that controls the humidity output value. This switch is set at the factory at the time of the order. The settings of the switch are shown at right in case you want to change them in the field. Be aware that the power requirements for the unit change depending on the humidity output value. See the specifications section for power requirements.



The black square represents the switch position, i.e., the "0-5 Vout" has all switches in the "off" position

**Appendix – Symbols Key**

 <b>Warning</b>	Potential for death, serious injury, or permanent damage to a system.
 <b>Caution</b>	Potential for injury, damage to a system, or system failure.
 <b>Tip</b>	Useful information not related to injury or system damage.